

**SP 108/150/300/360**



**aquamanta**<sup>TM</sup>  
the experts in aquatic technology



## ***Instruction Manual***



## Technical Information

<b>MODEL:</b>	SP 108	SP 150	SP 300	SP 360
<b>DIMENSIONS:</b>	130x64x62mm	145x82x67mm	144x72x69mm	185x84x78mm
<b>FLOW RATE:</b>	2L/min	2.5L/min	2x3L/min	2x3.5L/min
<b>WATTAGE:</b>	2.8W	3.5W	3.5W	4.5W
<b>PRESSURE:</b>	16kPa	20kPa	20kPa	22kPa
<b>OUTLETS:</b>	1	1	2	2

- Before operating the appliance, please read this manual carefully and keep it properly for future reference.
- Follow the instructions and the “important safeguards” in this manual before use.
- Please be aware of the guarantee conditions which are found at the end of this section of the instruction booklet. This product is shipped to you in a factory sealed carton. Should the product malfunction in any way or if the unit is damaged and requires replacement, contact the retailer where the product was purchased for inspection.
- Do not discard packing material until the product has been assembled.

# Important Safeguards

To guard against injury, basic safety precautions should be observed, including the following:

1. Read and follow all safety instructions and important notices in these instructions as well as on the product itself.
2. This appliance is not intended for use by children or infirm persons without supervision. Young children should be supervised to ensure that they do not play with the appliance.
3. To avoid possible electric shocks, special care should be taken since water is employed in the use of aquarium equipment. For each of the following situations do not attempt repairs yourself. Return the appliance to an authorised service facility for service or discard the appliance.
  - a. If the appliance or any electrical component of the appliance (non-immersible equipment only) falls into the water or gets wet, do not reach for it. Unplug it and then retrieve it.
  - b. If the appliance shows any sign of abnormal water leakage, immediately unplug it from the power source.
  - c. Carefully examine the appliance after installation. It should not be plugged in if there is water on parts which are not intended to be wet.
  - d. Do not operate the appliance if it has a damaged cord or plug, or if it is malfunctioning, or dropped or damaged in any manner.

4. A “drip loop” (see graphic) should be arranged for each cable connecting an aquarium to a power supply. The drip loop is the part of the cable below the level of the power supply. It prevents water travelling down the cable and coming into contact with the power supply. If the plug or the socket does get wet, do not unplug the appliance. Disconnect the fuse or circuit breaker that supplies the power to the appliance, then unplug and examine for presence of water in the socket.

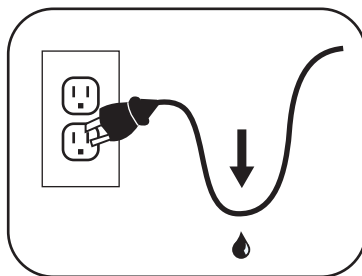

5. Always unplug the appliance from the electrical outlet when not in use, before putting on or taking off parts, before any type of maintenance or cleaning.
6. Never yank the cable to pull it from the socket. Pull the plug carefully to disconnect.
7. Do not use the appliance for reasons other than the intended use. The use of attachments that are not recommended or sold by the manufacturer may cause the product to be unsafe. This is not recommended.
8. Do not install or store the appliance where it will be exposed to weather or temperatures below freezing.
9. Make sure any component mounted on a tank is securely installed before operating it.
10. Ensure input voltage is the same voltage as your local power supply.
11. If an extension cable is used it should have the proper rating. Care should be taken to arrange the cord so that it will not be tripped or pulled.
12. A G.F.C.I (Ground fault circuit interrupter) & surge protector is recommended for all electrical appliances.
13. Ensure your hands are dry when turning the power switch on/off and when inserting/removing the power cable from the socket.
14. If you are in any doubt about the electrical installation or safety of this product you must consult a qualified electrician.

# Overview

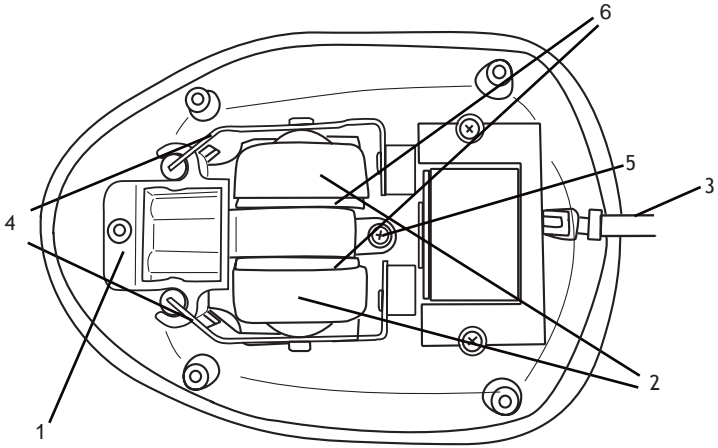

1. Air outlet unit
2. Diaphragm
3. Power cord
4. Diaphragm anchor
5. Air outlet manifold screw
6. Flapper valve assembly

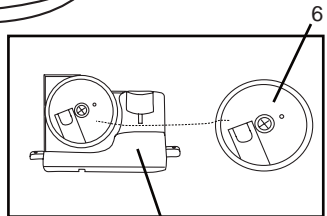
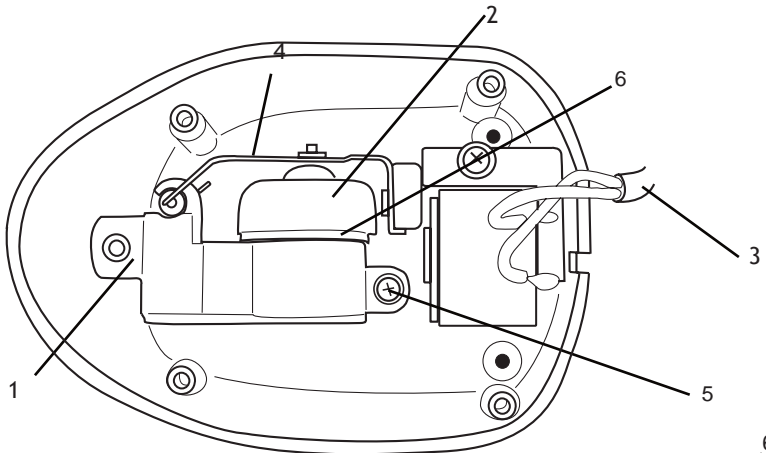

fig. 1

## Setup Instructions

1. Decide where you are going to position the air pump. Remember the pump must remain accessible for maintenance.
2. Where possible place the pump above the aquarium. Avoid placing the pump on a carpeted surface.
3. If not possible then ensure that a check valve (sold separately) is fitted to the airline. It is best to position the check valve as close to the aquarium as possible.
4. Attach one end of the air line into your ornament or air stone.
5. Attach the other end of the airline into the air outlet of your pump.
6. Position your pump. Ensure it is not going to vibrate off whatever surface you place it on.
7. Ensure your hands are dry, plug the pump in and turn on. Remember to arrange a drip loop.

## Maintenance

### Air stone

- Replace the air stone every 6 months or when it shows signs of deterioration.
- If being used in salt water a plastic or ceramic air stone is recommended.

### Diaphragm

- If pump is producing a lot of noise or the flow rate has reduced this may be an indication that the diaphragm assembly needs to be replaced.
  - Look for any tear or damage on the diaphragm.
  - To replace diaphragm assembly follow the instructions below.
1. Remove the 5 screws located in the bottom of the Pump.
  2. Lift top cover to reveal internals of pump.
  3. To remove diaphragm from assembly - Peel diaphragm off the air outlet unit
  4. Then push the diaphragm anchor towards the front of the air pump to remove.
  5. To replace diaphragm remove screw and nut on the diaphragm anchor.
  6. To replace flapper valve assembly remove the 2 air outlet manifold screws
  7. Remove the single screw from the flapper valve assembly fig(1)
  8. Replace flapper valve assembly(s)
  9. Then reassemble unit

NOTE: diaphragm assembly includes flapper valve assembly- Flapper valve assembly should be replaced simultaneously with the diaphragm.

# Troubleshooting

## PUMP DOES NOT WORK

1. Ensure the plug is inserted correctly and the power switch is in the on position

## THE MOTOR IS WORKING, BUT THERE IS NO AIR COMING OUT OF THE PUMP

1. Check that the air line is not kinked
2. Check the air stone and replace if needed
3. There is a rubber diaphragm inside the pump which may have worn out and may require replacing. Refer to Maintenance instructions.

## THE PUMP IS VERY NOISY

1. Check that the air line is not kinked
2. Check the air stone and replace if needed
3. There is a rubber diaphragm inside the pump which may have worn out and may require replacing. Consult your local Aquamanta dealer.
4. There may be too much back pressure on the pump. (It is too small for your application)

### **Disposal of used Electrical & Electronic Equipment (Applicable in the European Union and other European countries with separate collection systems)**



This symbol on the product or on its packaging indicates that the product must not be disposed of with normal household waste. Instead, it is your responsibility to dispose of your waste equipment by arranging to return it to a designated collection point for the recycling of waste electrical and electronic equipment. By separating and recycling your waste equipment at the time of disposal you will help to conserve natural resources and ensure that the equipment is recycled in a manner that protects human health and the environment. For more information about recycling this product, please contact your local city office, your household waste disposal service or the shop where you have purchased the product.

# Guarantee

The additional 1 Year Extended Guarantee applies when you REGISTER online with Aquamanta. Register your Extended Guarantee at [www.aquamanta.com.au](http://www.aquamanta.com.au)

## About this Guarantee

The Manufacturer or Distributor, of Aquamanta goods, is collectively known herein as “Aquamanta”. Please refer to contact details for Aquamanta below or on the applicable Aquamanta website. Any product that is covered by its own Guarantee (as enclosed with the product) is subject to the conditions of that Guarantee.

The benefits given to the purchaser, under Guarantee, are in addition to all other statutory rights and remedies which the purchaser has in respect of goods under legislation in the applicable country of purchase. This Guarantee shall not affect any such rights and should be read subject to such legislation.

### 1.0. Terms and Conditions of Guarantee.

1.1. Aquamanta warrants to the purchaser, for 2 Years from date of original purchase, to repair or replace goods where fault is found due to defective materials or faulty workmanship and where goods do not operate in accordance with the instructions.

1.2. All claims for repair or replacement must be made at place of purchase.

1.3. The original and dated Proof of Purchase (receipt) must be supplied with all goods claims. Please also provide this Guarantee where possible.

1.4. The Guarantee covers the Aquarium against gluing breakdown resulting in leakage.

1.5. All goods subject to claim under Guarantee should be prepared for transportation in the original packaging or other comparable packaging which offers the same degree of protection.

1.6. Where goods are repaired or replaced under Guarantee, these goods are Guaranteed for the remainder of either the original Guarantee or Extended Guarantee period.

1.7. Where claims on inspection reveal goods are in normal working order, Aquamanta will request reimbursement of all reasonable costs incurred.

### 2.0. Other Terms and Conditions - Extended Guarantee

2.1. The Extended Guarantee period is for an additional 1 Year and commences on expiration of the standard guarantee period.

2.2. Application for Extended Guarantee is FREE of any registration cost to the purchaser on completion of the Extended Guarantee questionnaire which is found on the applicable Aquamanta website (refer below).

2.3. Upon receipt and acceptance of the questionnaire, Aquamanta will forward (by way of email) a Certificate of Extended Guarantee to the purchaser.

2.4. For more information on how we collect, hold, use and disclose personal information provided to us, please refer to our Privacy Statement on the Aquamanta websites or write to our Privacy Officer, in your country of purchase.

2.5. Where Aquamanta determines goods are being used in a manner contrary to the instructions, specifications or this Guarantee, Aquamanta reserves the right to terminate Extended Guarantee for such goods and will provide written notice to the purchaser.

### 3.0. Exclusions and Limitations

Where permitted by local law, the following exclusions and limitations apply in regard to Guarantee:

3.1. Goods claims where fault is due to, but not limited by a) misuse b) neglect c) abuse d) fire or flood e) normal wear and tear f) accidental breakage g) Acts of God h) mains voltage fluctuation or supply problems i) connection to any voltage other than what is stated on the rating plate j) modification or tampering to electrical cord or plug, k) vermin, insects or foreign object l) liquid spillage or submersion of goods not designed to sustain such use or duress.

3.2. Where inspections reveal goods are in normal working order including where noise or vibration is consistent with normal goods operation.

3.3. Attempted repairs or modifications by unauthorised persons, including but not limited to the drilling of holes in the aquarium glass by unauthorised persons.

3.4. Where the goods factory rating plate has been removed, altered, damaged or is rendered illegible.

3.5. Where goods are not installed, operated or maintained in accordance with Aquamanta's goods instructions, specifications or this Guarantee.

3.6. Replacement or repair of worn consumables or replacement of lost goods, parts or components.

3.7. Costs associated with goods transportation, removal, installation, postage or cost of insurance.

3.8. Any damage incurred whilst installing, transporting or moving the goods.

3.9. Subject to certain local statutory rights and obligations to the contrary, and this guarantee shall not affect those rights or obligations, where, to the full extent permitted by law: 1. all express and implied warranties and conditions under statute or general law, are expressly excluded and Aquamanta, where permitted, will limit liability as follows and at Aquamanta's option to: in regard to goods either a) the replacement of goods or supply of equivalent goods b) the repair of goods or the cost of replacing the goods or of acquiring equivalent goods OR in regard to services either c) the re-supply of services d) the cost to re-supply services.

2. Aquamanta will not be liable for any loss or damage, including consequential loss or damage either directly or indirectly, or for any incidental expenses, of any kind, and in any way whatsoever.

The additional 1 Year Extended Guarantee applies when you REGISTER online with Aquamanta. Register your Extended Guarantee at [www.aquamanta.com.au](http://www.aquamanta.com.au)

(1) Consumables include items such as filter media/cartridges, impellers and shafts, and diaphragms/flapper valves.

Aquamanta may be contacted in:  
Australia  
Kong's (Aust.) Pty. Limited  
PO Box 863, Ingleburn  
1890 NSW Australia



**aquamanta**<sup>TM</sup>  
the experts in aquatic technology

Manufactured in China  
Aquamanta and Kong's are registered  
trademarks of Kong's (Aust.) Pty Limited.  
[www.aquamanta.com.au](http://www.aquamanta.com.au)



Instruction version: 15/03/2012